

REV	DESCRIPTION\PER REQUEST	DRAWN	DATE

CRIMP SIZES REQUIRED  
CONTACT: .128[3.3mm]  
FERRULE: .429[10.9mm]

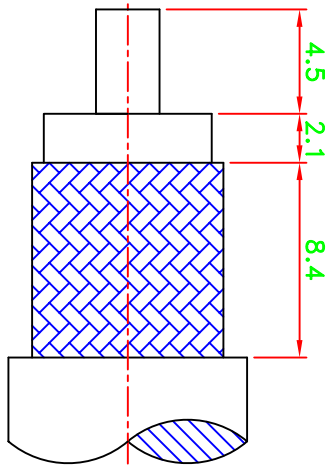

RECOMMENDED  
STRIPPING DIMENSIONS

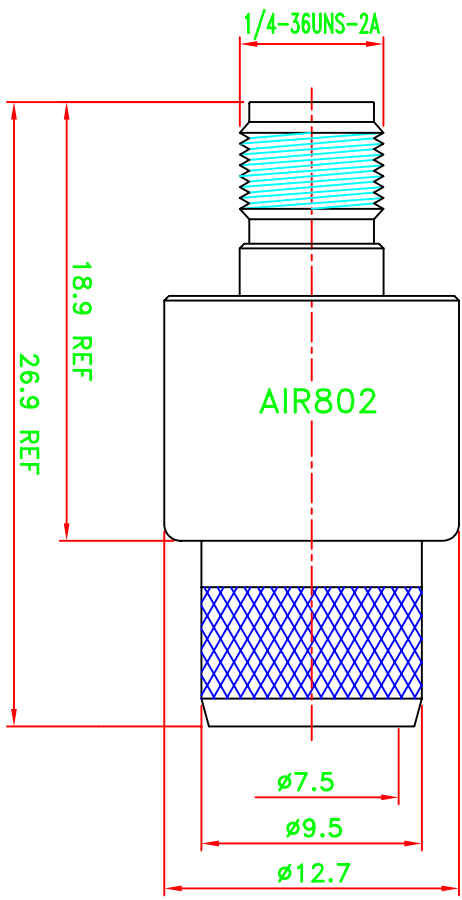
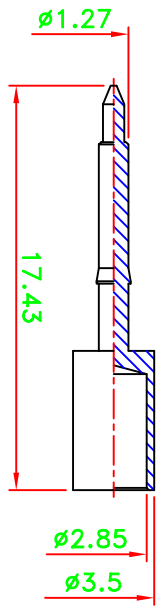

NOTES:  
1. UNLESS OTHERWISE SPECIFIED ALL DIMENSIONS ARE IN MM.  
2. ALL SPECIFICATIONS ARE SUBJECT TO CHANGE WITHOUT NOTICE AT ANY TIME.

NO	Description	Qty	Material	Finish
5	Ferrule	1	Brass	Nickel
4	Press fit ferrule stud	1	Brass	Nickel
3	Dielectric	1	Teflon	None
2	Pin	1	Brass	Gold
1	Body	1	Brass	Nickel

PART NO.	CN4RSJC
APPROVED	M. BRYANT
CHECKED	
DRAWN	Vivian
DATE	10/20/06

* MAJOR DIMENSION	UNLESS OTHERWISE NOTED TOLERANCES
SCALE	3/1
UNIT	mm
ANGLES	±1.0

TITLE	AIR802 LLC
DRAWING NO.	RP-SMA JACK CRIMP
FILE NO.	ASSMA-10248-T-RP-TGN
REV	A
	AIR802-->20070802

