

REV	DESCRIPTION \ PER REQUEST	DRAWN	DATE

NOTES:
 1. UNLESS OTHERWISE SPECIFIED ALL DIMENSIONS ARE IN MM.
 2. ALL SPECIFICATIONS ARE SUBJECT TO CHANGE WITHOUT NOTICE AT ANY TIME.

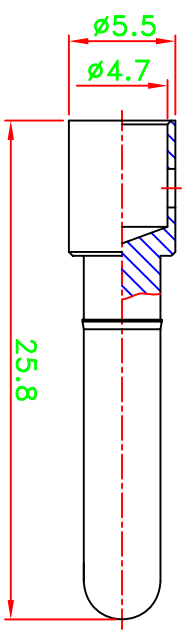

CRIMP SIZES REQUIRED
 CONTACT: SOLDER
 FERRULE: .625" HEX CRIMP

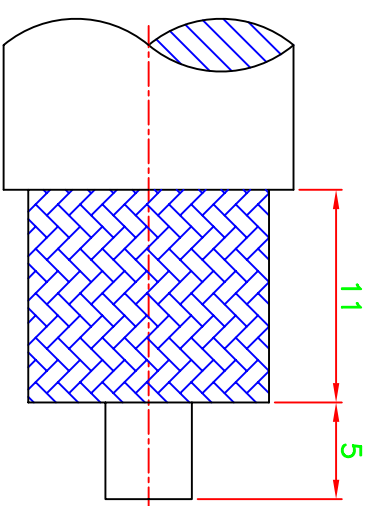

RECOMMENDED
 CABLE STRIPPING DIM'S

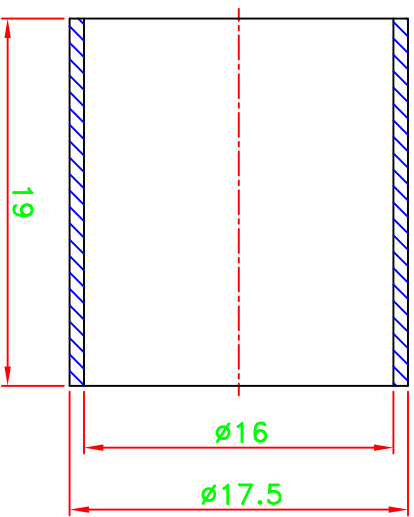

NOTES: FINISH (PLATING THICKNESS IN MICRO-INCHES)
 1. COPPER-TIN-ZINC PL. 100 MIN THICK

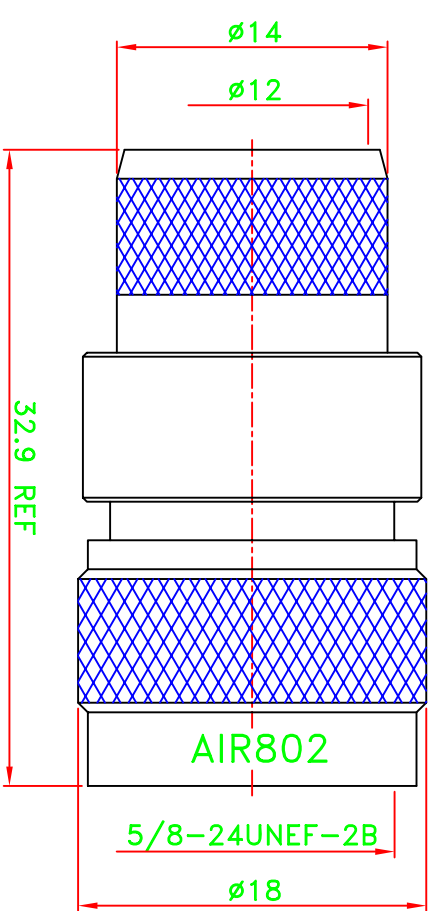

STAMP: AIR802

NO	Description	Qty	Material	Finish
6	Ferrule	1	Brass	NOTE 1
5	Shell	1	Brass	NOTE 1
4	Retaining ring	1	Brass	NOTE 1
3	Dielectric	1	Teflon	None
2	Pin	1	Brass	Gold
1	Body	1	Brass	NOTE 1

PART NO. CN6UHFP		UNLESS OTHERWISE NOTED TOLERANCES	
APPROVED	M. BRYANT	DATE	03/25/10
CHECKED		DATE	03/25/10
DRAWN	WEN	DATE	03/25/10
SCALE	5/2	UNIT	mm
TITLE		DRAWING NO.	
UHF CRIMP PLUG		ASUHF-17028-V	
AIR802 LLC		REV A	
FILE NO. W:\ASUHF\ASUHF-17028-V		DIANA->20100326	