

REV	DESCRIPTION \ PER REQUEST	DRAWN	DATE

CRIMP SIZES REQUIRED
CONTACT: .128" [3.3mm]
FERRULE: .429" [10.9mm]

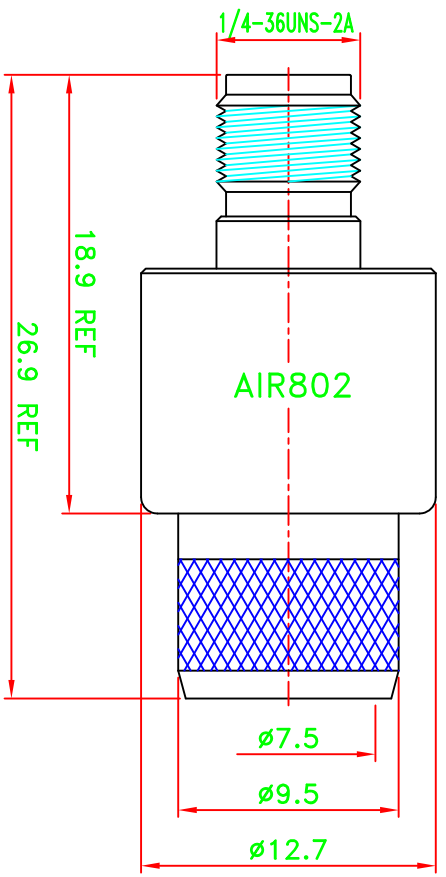

NOTES:
 1. UNLESS OTHERWISE SPECIFIED ALL DIMENSIONS ARE IN MM.
 2. ALL SPECIFICATIONS ARE SUBJECT TO CHANGE WITHOUT NOTICE.

STAMP: AIR802

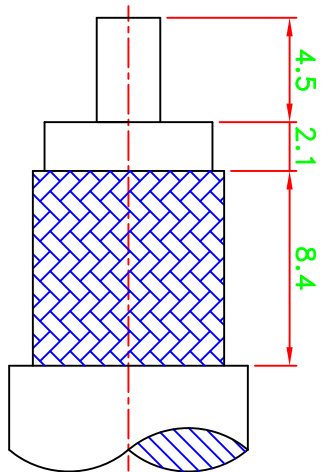

**RECOMMENDED
 CABLE STRIPPING DIM'S**

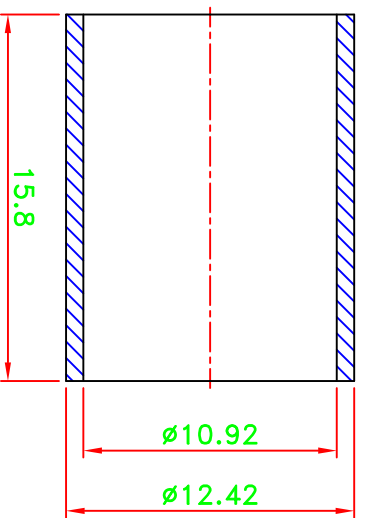
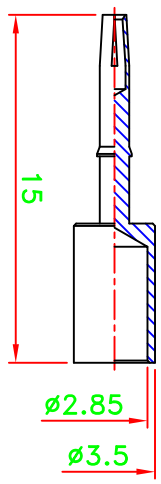

NO	Description	Qty	Material	Finish
5	Ferrule	1	Brass	Nickel
4	Press fit ferrule stud	1	Brass	Nickel
3	Dielectric	1	Teflon	None
2	Pin	1	Brass	Gold
1	Body	1	Brass	Nickel

PART NO.	APPROVED	CHECKED	DRAWN
CN4SMAJ	M. Bryant		WEN
DATE	DATE	DATE	DATE
04/27/12	04/27/12	04/27/12	04/27/12

* MAJOR DIMENSION	UNLESS OTHERWISE NOTED TOLERANCES
0.5-6	±0.2
6-30	±0.4
30-120	±0.6
120-315	±1.0
ANGLES	±1°

TITLE	DRAWING NO.	FILE NO.	SCALE	UNIT	mm
AIR802 LLC	SMA CRIMP JACK	W:\72~\AS\ASSMA\ASSMA-10248-T-TGN	3/1	mm	
	ASSMA-10248-T-TGN				

70C00V001-003