

REV	DESCRIPTION \ PER REQUEST	DRAWN	DATE

NOTES:
 1. UNLESS OTHERWISE SPECIFIED ALL DIMENSIONS ARE IN MM.
 2. ALL SPECIFICATIONS ARE SUBJECT TO CHANGE WITHOUT NOTICE
 AT ANY TIME.

CRIMP SIZES REQUIRED
 CONTACT: .128[3.3mm]
 FERRULE: .429[10.9mm]

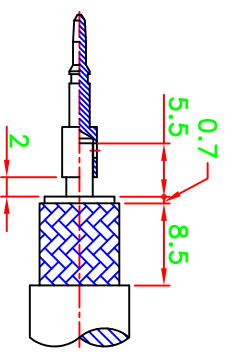
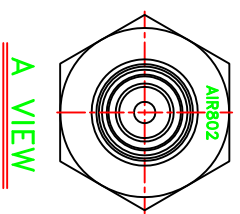
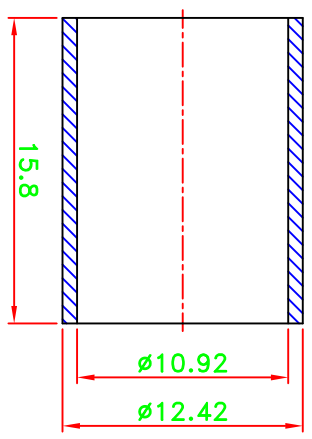
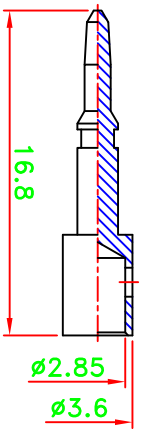
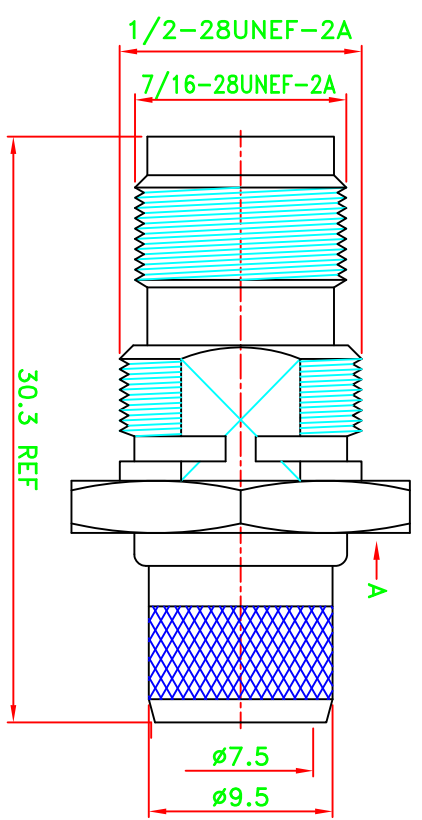
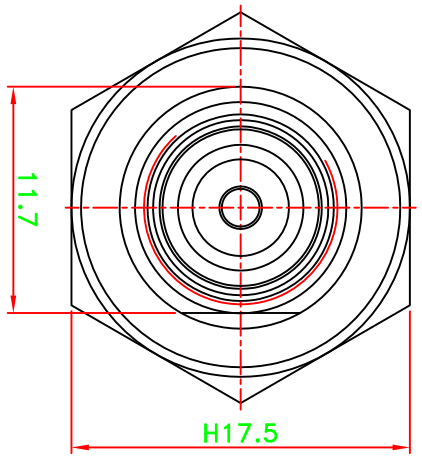

RECOMMENDED
 CABLE STRIPPING DIM'S

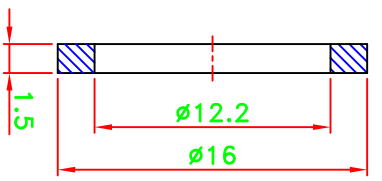
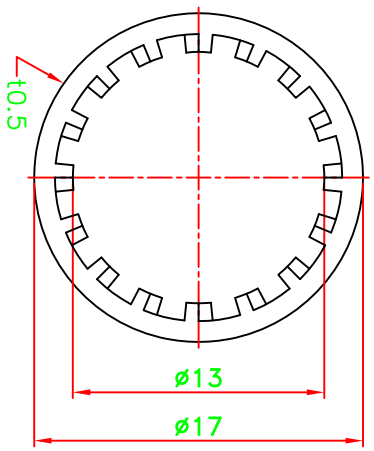
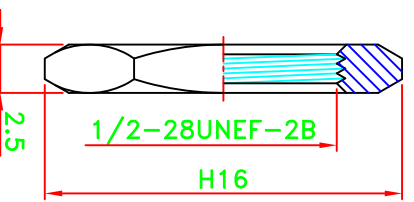
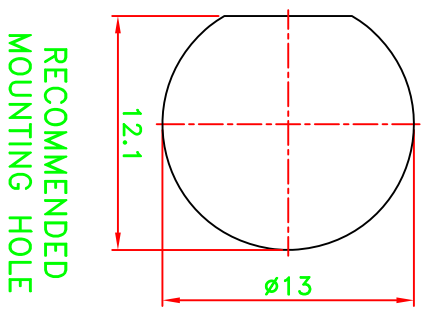

15C00V301-000

NO	Description	Qty	Material	Finish
8	Nut	1	Brass	Nickel
7	Washer	1	Iron	Nickel
6	Gasket	1	Rubber	Red
5	Ferrule	1	Brass	Nickel
4	Press fit ferrule stud	1	Brass	Nickel
3	Dielectric	1	Teflon	None
2	Pin	1	Brass	Gold
1	Body	1	Brass	Nickel

PART NO.	CN4RTJB
APPROVED	M. Bryant
CHECKED	
DRAWN	Wen
DATE	03/08/13

UNLESS OTHERWISE NOTED TOLERANCES	* MAJOR DIMENSION
0.5-6 = ±0.2	
6-30 = ±0.4	
30-120 = ±0.6	
120-315 = ±1.0	
ANGLES = ±1°	

TITLE	TNC R/P BULKHEAD CRIMP JACK
DRAWING NO.	ASTNC-15173-T-RP-50-TGN
REV	A
FILE NO.	W:\P\~\AS\ASTNC\ASTNC-15173-T-RP-50-TGN AIR802->20130311

AIR802 LLC