

REV	DESCRIPTION\PER REQUEST	DRAWN	DATE

CRIMP SIZES REQUIRED
CONTACT: .068[1.75mm]
FERRULE: .256[6.5mm]

- NOTES:
1. UNLESS OTHERWISE SPECIFIED ALL DIMENSIONS ARE IN MM.
2. ALL SPECIFICATIONS ARE SUBJECT TO CHANGE WITHOUT NOTICE AT ANY TIME.

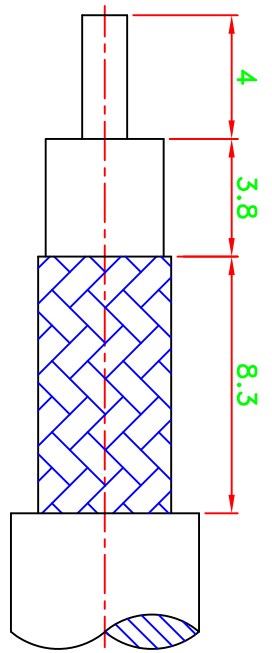
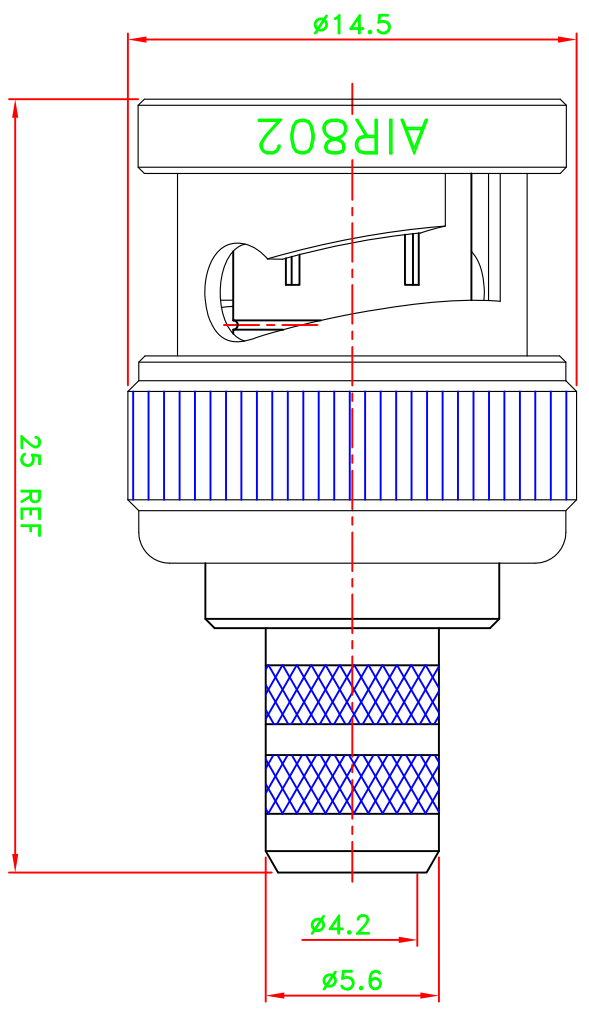

RECOMMENDED
CABLE STRIPPING DIM'S

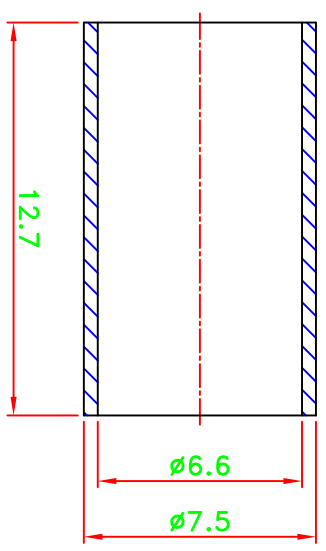
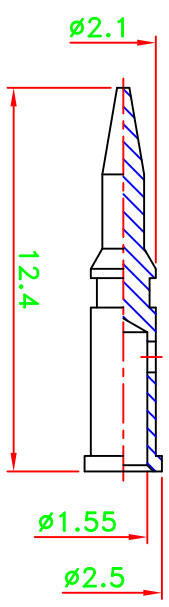

NO	Description	Qty	Material	Finish
9	Ferrule	1	Brass	Nickel
8	Shell	1	Brass	Nickel
7	Gasket	1	Rubber	Red
6	Retaining ring	1	SK5	Nickel
5	Spring	1	SK5	Nickel
4	Washer	1	Brass	Nickel
3	Dielectric	1	Teflon	None
2	Pin	1	Brass	Gold
1	Body	1	Brass	Nickel

STAMP: AIR802

PART NO.	CN3BNCM
APPROVED	M. Bryant
CHECKED	Kdi
DRAWN	Kdi
DATE	08/08/12

* MAJOR DIMENSION	UNLESS OTHERWISE NOTED TOLERANCES
SCALE	4/1
UNIT	mm
FILE NO.	W:\P\AS\ASBNC\ASBNC-13335-Z-50-TGN

TITLE		AIR802 LLC	
DRAWING NO.		ASBNC-13335-Z-50-TGN	
REV		A	