

REV	DESCRIPTION \ PER REQUEST	DRAWN	DATE

NOTES:
 1. UNLESS OTHERWISE SPECIFIED ALL DIMENSIONS ARE IN MM.
 2. ALL SPECIFICATIONS ARE SUBJECT TO CHANGE WITHOUT NOTICE.

CRIMP SIZES REQUIRED
 CONTACT: 0.1 [2.54mm]
 FERRULE: .213 [5.4mm]

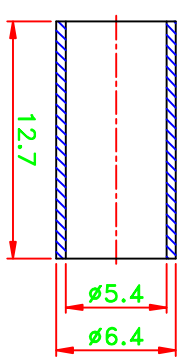
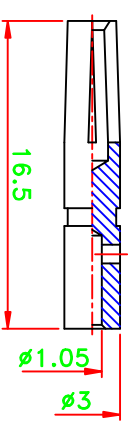
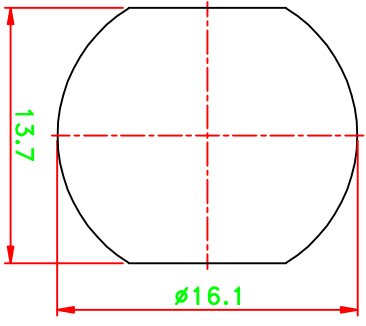
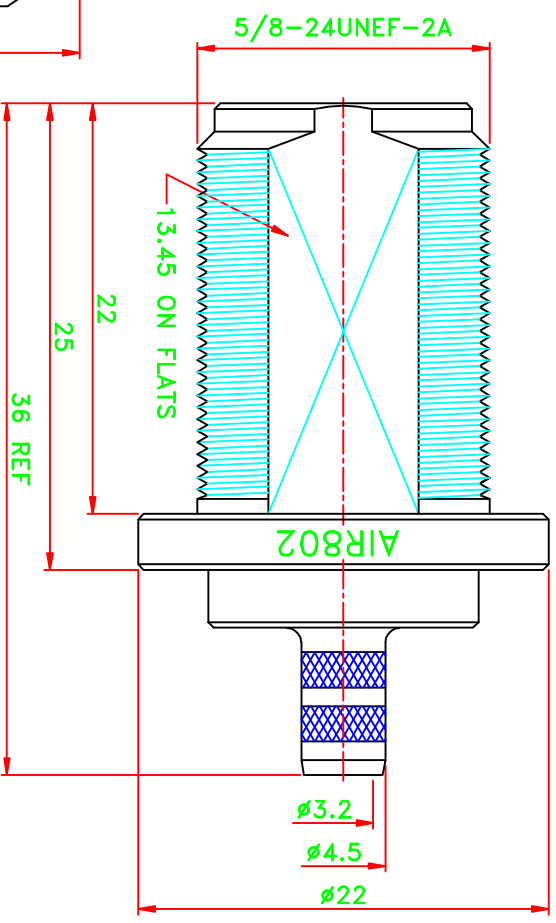
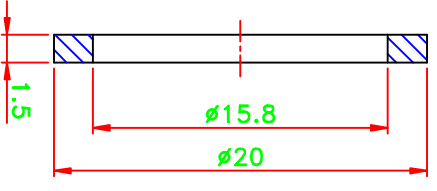
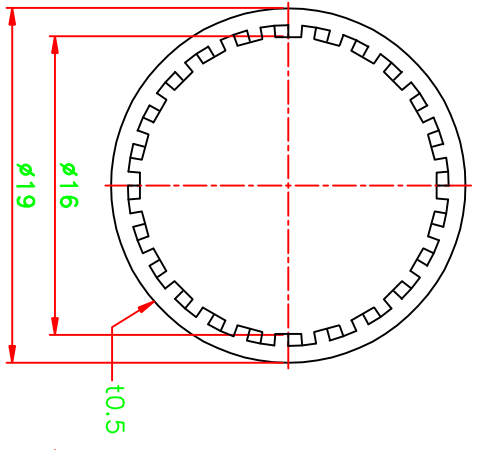
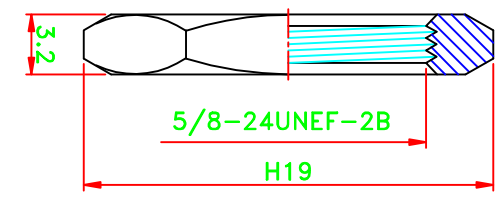
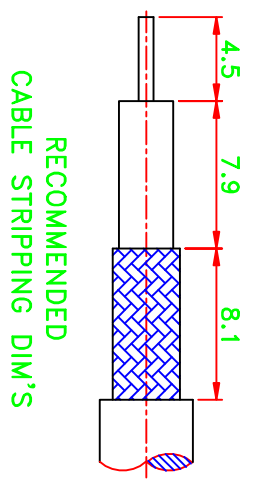

STAMP: AIR802

NO	Description	Q'ty	Material	Finish
8	Nut	1	Brass	Nickel
7	Washer	1	Brass	Nickel
6	Gasket	1	Si-rubber	Red
5	Ferrule	1	Brass	Nickel
4	Press fit ferrule stud	1	Brass	Nickel
3	Dielectric	1	Teflon	None
2	Pin	1	Brass	Gold
1	Body	1	Brass	Nickel

60C00V201-001

PART NO.	CN2NFB	* MAJOR DIMENSION	UNLESS OTHERWISE NOTED TOLERANCES	TITLE	AIR802 LLC
APPROVED	M. Bryant	DATE	03/24/11	0.5-6 = ± 0.2	N BULKHEAD CRIMP JACK
CHECKED		DATE	03/24/11	6-30 = ± 0.4	
DRAWN	WEN	DATE	03/24/11	30-120 = ± 0.6	
SCALE	5/2	UNIT	mm	120-315 = ± 1.0	DRAWING NO.
				ANGLES = $\pm 1^\circ$	ASN-11202-F-TGN
					REV A
					FILE NO. \\ Songtech \ XDWG \ X-0356.DWG
					DIANA->20110325