

REV	DESCRIPTION \ PER REQUEST	DRAWN	DATE

CRIMP SIZES REQUIRED
CONTACT: .069 [1.75mm]
FERRULE: .213[5.4mm]

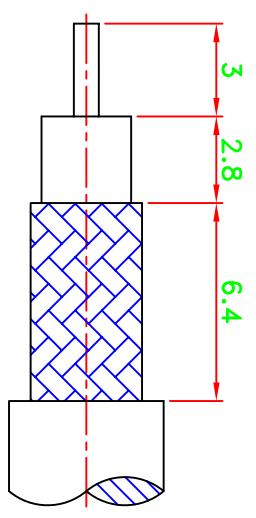

RECOMMENDED
CABLE STRIPPING DIM'S

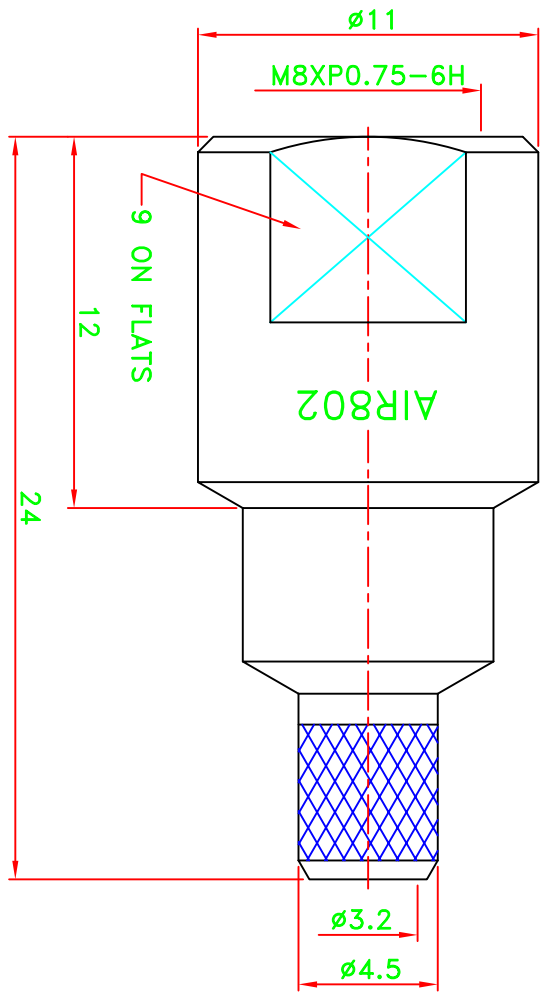

STAMP: AIR802

NOTES:
1. UNLESS OTHERWISE SPECIFIED ALL DIMENSIONS ARE IN MM.
2. ALL SPECIFICATIONS ARE SUBJECT TO CHANGE WITHOUT NOTICE AT ANY TIME.

NO	Description	Qty	Material	Finish	PART NO.	APPROVED	CHECKED	DRAWN	DATE	* MAJOR DIMENSION	UNLESS OTHERWISE NOTED TOLERANCES	TITLE	DRAWING NO.	FILE NO.	REV
4	Ferrule	1	Brass	Nickel	CN2FMEP	M. BRYANT		WEN	08/12/10	0.5-6 = ±0.2	6-30 = ±0.4	AIR802 LLC	FME CRIMP PLUG	W:\DWG\COMPONENTS\FME\FME-2001-F2-TGN	A
3	Dielectric	1	Teflon	None						30-120 = ±0.6	120-315 = ±1.0				
2	Pin	1	Brass	Gold						ANGLES = ±1.0					
1	Body	1	Brass	Nickel											

