

REV	DESCRIPTION \ PER REQUEST	DRAWN	DATE

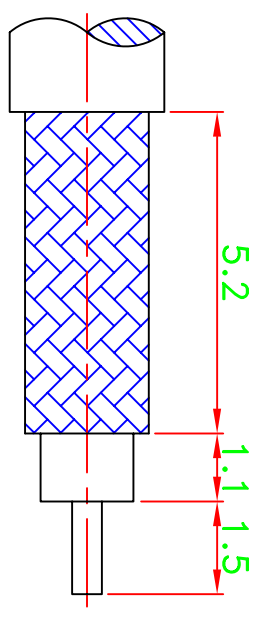

RECOMMENDED  
CABLE STRIPPING DIM'S

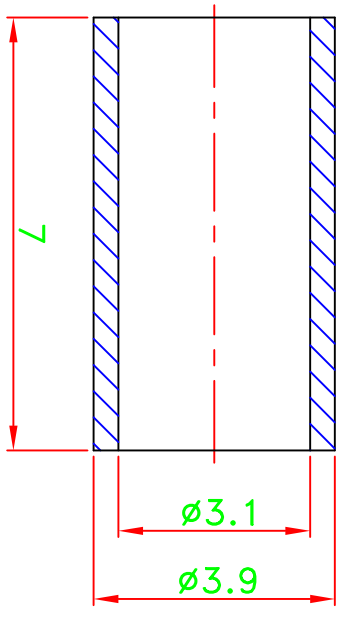

NO	Description	Qty	Material	Finish
7	Ferrule	1	Copper	Gold
6	Retaining ring	1	Beryllium	Gold
5	Cap	1	Brass	Gold
4	Dielectric	1	Teflon	None
3	Dielectric	1	Teflon	None
2	Pin	1	Brass	Gold
1	Body	1	Brass	Gold

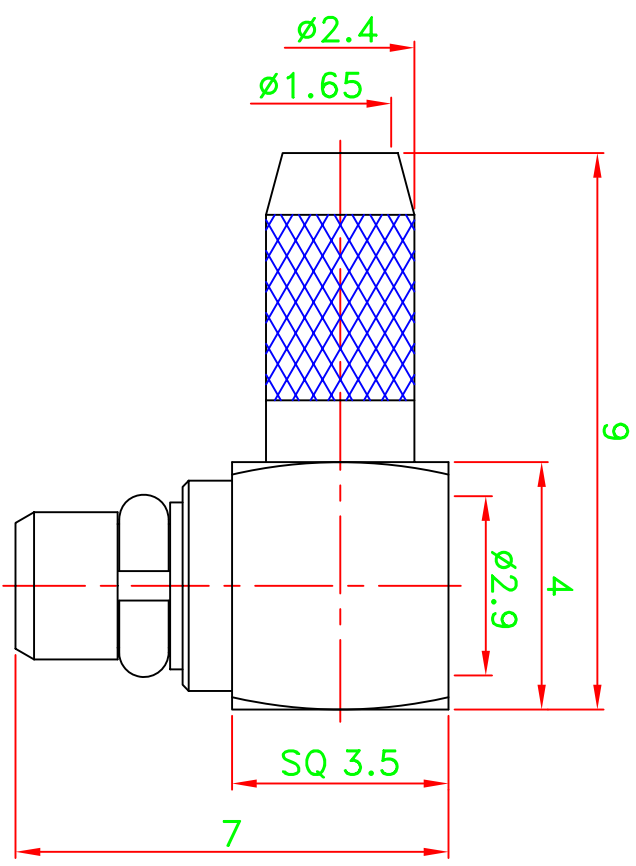
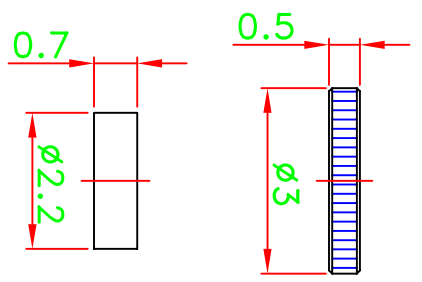

NOTES:  
1. UNLESS OTHERWISE SPECIFIED ALL DIMENSIONS ARE IN MM.  
2. ALL SPECIFICATIONS ARE SUBJECT TO CHANGE WITHOUT NOTICE.

PART NO.	CN1MMPR	* MAJOR DIMENSION	UNLESS OTHERWISE NOTED TOLERANCES	TITLE	MMCX R/A CRIMP PLUG
APPROVED	M. Bryant	DATE	06/23/08	DRAWING NO.	MMCX-802-L11-TGG
CHECKED		DATE	06/23/08	FILE NO.	W:\DWG\COMPOSE\MMCX\MMCX-802-L11-TGG
DRAWN	WEN	DATE	06/23/08	SCALE	8/1
		UNIT	mm	ANGLE	±1.0
				REV	A

**AIR802 LLC**

CRIMP SIZES REQUIRED  
CONTACT: SOLDER  
FERRULE: .128[3.75mm]